



Community Development - Building Division
2200 Civic Center Place
Miramar, Florida 33025
Tel: (954) 602-3200 Fax: (954) 602-3635
<http://www.ci.miramar.fl.us>

Service Change Package

Quick service is available on Tuesdays from 8am to 10am if all requirements are met

Required inspections:

- 999 Final Inspection

Application Checklist

- Owner/builder affidavit (if permit is by homeowner)
- Permit Application
- Job contract - completed and signed by all parties
- Notice of Commencement - (**Original or Certified**), if the job value is \$2,500 or more
- One-Line Diagram – (**2 copies**) Signed and notarized

***Application must indicate contract value (labor and material).**

***The job description must detail the complete scope of work.**

***Florida Power & Light must be contacted to schedule the disconnect and reconnect, prior to calling for the final electrical inspection.**

***All inspections must be called in prior to 3:00 pm to be scheduled for the next business day.**

***If you need a time frame for the final electrical inspection you can call 954-602-3202 between 7:30 – 8:00 am the morning of the inspection.**

***Notice of commencement, if applicable, must be filed at the Broward County Government Center / Records Division 115 S. Andrews Ave (954) 357-7283. Or the Recording Office located at 1800 NW 66 Ave. Suite #101. Plantation FL. 33313. (954)831-4000**

ATTENTION HOMEOWNERS

- Permit application and owner/builder affidavit must be notarized by Building Division Clerks. Outside notaries will not be accepted.
- Proof of ownership is required (recorded warranty deed, tax statement, settlement statement).
- Homeowner must appear in person with a valid picture ID (driver's license, ID card, etc.). The address on ID must be the same as proof of ownership.
- If a contractor is hired, the contractor must pull the permit.



CITY OF MIRAMAR • COMMUNITY DEVELOPEMT • BUILDING DIVISION
OWNER-BUILDER DISCLOSURE STATEMENT

YOU HAVE MADE APPLICATION FOR A BUILDING PERMIT AS AN OWNER-BUILDER. STATE LAW REQUIRES CONSTRUCTION TO BE DONE BY LICENSED CONTRACTORS. YOU HAVE APPLIED FOR A PERMIT UNDER AN EXEMPTION TO THAT LAW. PLEASE BE ADVISED OF THE FOLLOWING PROVISIONS AS PER FLORIDA STATUTES F.S. 489 .103(7).

1. I understand that state law requires construction to be done by a licensed contractor and have applied for an owner-builder permit under an exemption from the law. The exemption specifies that I, as the owner of the property listed, may act as my own contractor with certain restrictions even though I do not have a license.
2. I understand that building permits are not required to be signed by a property owner unless he or she is responsible for the construction and is not hiring a licensed contractor to assume responsibility.
3. I understand that, as an owner-builder, I am the responsible party of record on a permit. I understand that I may protect myself from potential financial risk by hiring a licensed contractor and having the permit filed in his or her name instead of my own name. I also understand that a contractor is required by law to be licensed in Florida and to list his or her license numbers on permits and contracts.
4. I understand that I may build or improve a one-family or two-family residence or a farm outbuilding. I may also build or improve a commercial building if the costs do not exceed \$75,000. The building or residence must be for my own use or occupancy. It may not be built or substantially improved for sale or lease. If a building or residence that I have built or substantially improved myself is sold or leased within 1 year after the construction is complete, the law will presume that I built or substantially improved it for sale or lease, which violates the exemption.
5. I understand that, as the owner-builder, I must provide direct, onsite supervision of the construction.
6. I understand that I may not hire an unlicensed person to act as my contractor or to supervise persons working on my building or residence. It is my responsibility to ensure that the persons whom I employ have the licenses required by law and by county or municipal ordinance.
7. I understand that it is a frequent practice of unlicensed persons to have the property owner obtains an owner-builder permit that erroneously implies that the property owner is providing his or her own labor and materials. I, as an owner-builder, may be held liable and subjected to serious financial risk for any injuries sustained by an unlicensed person or his or her employees while working on my property. My homeowner's insurance may not provide coverage for those injuries. I am willfully acting as an owner-builder and am aware of the limits of my insurance coverage for injuries to workers on my property.
8. I understand that I may not delegate the responsibility for supervising work to a licensed contractor who is not licensed to perform the work being done. Any person working on my building who is not licensed must work under my direct supervision and must be employed by me, which means that I must comply with laws requiring the withholding of federal income tax and social security contributions under the Federal Insurance Contributions Act (FICA) and must provide workers' compensation for the employee. I understand that my failure to follow these laws may subject me to serious financial risk.
9. I agree that, as the party legally and financially responsible for this proposed construction activity, I will abide by all applicable laws and requirements that govern owner-builders as well as employers. I also understand that the construction must comply with all applicable laws, ordinances, building codes, and zoning regulations.
10. I understand that I may obtain more information regarding my obligations as an employer from the Internal Revenue Service, the United States Small Business Administration, the Florida Department of Financial Services, and the Florida Department of Revenue. I also understand that I may contact the Florida Construction Industry Licensing Board at **(850)487-1395** or <http://www.myfloridalicense.com/dbpr/pro/cilb/index.html> for more information about licensed contractors.
11. I am aware of, and consent to, an owner-builder building permit applied for in my name and understand that I am the party legally and financially responsible for the proposed construction activity at my property address .
12. I agree to notify immediately of any additions, deletions, or changes to any of the information that I have provided on this disclosure.

Licensed contractors are regulated by laws designed to protect the public. If you contract with a person who does not have a license, the Construction Industry Licensing Board and Department of Business and Professional Regulation may be unable to assist you with any financial loss that you sustain as a result of a complaint. Your only remedy against an unlicensed contractor may be in civil court. It is also important for you to understand that, if an unlicensed contractor or employee of an individual or firm is injured while working on your property, you may be held liable for damages. If you obtain an owner-builder permit and wish to hire a licensed contractor, you will be responsible for verifying whether the contractor is properly licensed and the status of the contractor's workers' compensation coverage. Before a building permit can be issued, this disclosure statement must be completed and signed by the property owner and returned to the local permitting agency responsible for issuing the permit. **A copy of the property owner's driver license, the notarized signature of the property owner, or other type of verification acceptable to the local permitting agency is required when the permit is issued.**

ACKNOWLEDGMENT: I HAVE READ THE FOREGOING INSTRUCTIONS AND I AM AWARE OF MY RESPONSIBILITIES. I HEREBY SWEAR AND AFFIRM THAT I AM THE OWNER OF THE PROPERTY DESCRIBED AS:

LOT : _____ BLOCK: _____ SUBDIVISION: _____
ADDRESS: _____ CITY : **MIRAMAR** STATE : **FLORIDA** ZIP CODE _____

Signature Date Signed
STATE OF FLORIDA , COUNTY OF BROWARD Sworn to and subscribed before me this _____ day of _____, 20_____.

Notary Public



2200 Civic Center Place • Miramar, Florida 33025

Tel: (954) 602-3200 • Fax: (954) 602-3635

www.ci.miramar.fl.us

PERMIT APPLICATION

Permit Type (Check one): STRUCTURAL ELECTRICAL MECHANICAL PLUMBING LANDSCAPING

Date _____ Tax Folio # _____ Master # _____
Owner Name _____ Permit # _____
 Owner Address _____ City, State, Zip _____
 E-Mail _____ Phone # _____

Contractor Company Name _____
 Contractor Address _____ City, State, Zip _____
 State Certificate or Registration _____ Phone # _____
 Certificate of Competency _____ Fax # _____
 E-Mail _____
 Architect / Engineer _____ Phone # _____

Job Name _____ Community Gate Code _____
 Job Address _____ **Miramar, FL** Zip _____
 Subdivision _____ Lot _____ Blk _____
 Type of Work New Existing Commercial Residential Addition Alteration Repair
 Use/Occupancy _____ No. of Stories _____ Bed _____ Bath _____
 Job Description _____

WARNING TO OWNER: YOUR FAILURE TO RECORD A *NOTICE OF COMMENCEMENT* MAY RESULT IN YOUR PAYING TWICE FOR IMPROVEMENTS TO YOUR PROPERTY. IF YOU INTEND TO OBTAIN FINANCING, CONSULT WITH YOUR LENDER OR AN ATTORNEY BEFORE RECORDING YOUR NOTICE OF COMMENCEMENT.

Linear / Sq. Ft. _____
 Contract Value _____
 Estimated Cost _____

Application is hereby made to obtain a permit to do work and installations as indicated. I certify that no work or installation has commenced prior to the issuance of a permit and that all work will be performed to meet the standards of all laws regulating construction in the City of Miramar, Florida. I understand that a separate permit must be secured for ELECTRICAL, PLUMBING, SIGNS, WELLS, POOLS, HEATERS, AIR CONDITIONERS, ROOF etc.

PERMIT APPLICANT AFFIDAVIT: I certify that all the foregoing information is accurate and that all work will be done in compliance with applicable laws regulating construction and zoning.

Signature _____
 Contractor (Qualifier) * If Permit is by Owner, the owner must sign

Print Name _____

State of Florida, Broward County

On this _____ day of _____ 20 _____ the person whose name is subscribed to within this instrument, personally appeared before / personally known to me, the undersigned Notary Public of the State of Florida, and he / she acknowledges that he / she executed it.

O	Permit Fee	_____
F	Plan Review	_____
F	Training	_____
I	Radon	_____
C	Constr. Fund	_____
E	Brow. Surv.	_____
U	7% Surcharge	_____
S	Total →	_____

NOTICE: In addition to the requirements of this permit, there may additional restrictions applicable to this property that may be found in the public records of this county.

This permit does not become valid until signed by the Building Official (or designated employee) of the City of Miramar and all fees are paid.

Notary Public, State of Florida

Authorized Signature

Plans & permit must be on job before inspection will be made. For new constructions (Commercial & Residential) and Commercial Interior Build-out, a Certificate of Occupancy shall be obtained from Building Division before using completed Building.

NOTICE OF COMMENCEMENT

this space reserved for recorder

The undersigned hereby gives notice that improvement will be made to certain real property, and in accordance with Chapter 713, Florida Statutes, the following information is provided in this Notice of Commencement:

1. Legal Description of Property: Lot _____ Block _____ Unit # _____ Bldg # _____ Lengthy legal attached
Subdivision/Condominium: _____

Street Address if available: _____

2. General Description of Improvement: _____

3.a. Owner name and address: _____

b. Interest in property: _____

c. Name/mailling address of fee simple title holder (if other than Owner): _____

4. a. Contractor name and address: _____

b. Contractor's phone number: _____

5. a. Surety name and address: _____

b. Surety's phone number: _____

c. Amount of bond: \$ _____

6. a. Lender name and address: _____

b. Lender's phone number: _____

7. a. Persons within the State of Florida designated by Owner upon whom Notices or other documents may be served as provided by Section 713.13(1)(A)7., Florida Statutes:

Name: _____

Address: _____

b. Phone Number: _____

8. a. In addition to himself or herself, the Owner designates _____ to receive a copy of the Lienor's Notice per section 713.13(1)(B), Florida Statutes:

b. Phone number of person or entity designated by owner _____

9. Expiration date of notice of commencement: _____

(the expiration date is 1 year from date of recording unless a different date is specified).

WARNING OT OWNER: ANY PAYMENTS MADE BY THE OWNER AFTER THE EXPIRATION OF THE NOTICE OF COMMENCEMENT ARE CONSIDERED IMPROPER PAYMENTS UNDER CHAPTER 713, PART 1, SECTION 713.13 FLORIDA STATUTES, AND CAN RESULT IN YOU PAYING TWICE FOR IMPROVEMENTS TO YOUR PROPERTY. A NOTICE OF COMMENCEMENT MUST BE RECORDED AND POSTED ON THE JOB SITE BEFORE THE FIRST INSPECTION. IF YOU INTEND TO OBTAIN FINANCING, CONSULT WITH YOUR LENDER OR AN ATTORNEY BEFORE COMMENCING WORK OR RECORDING YOUR NOTICE OF COMMENCEMENT.

Signature(s) of Owner(s) or Owner(s)' Authorized Officer/Director/Partner/ Manager

By _____ By _____
Print Name _____ Print Name _____
Title/Office _____ Title/Office _____

STATE OF FLORIDA
COUNTY OF BROWARD

The forgoing instrument was acknowledged before me this _____ day of _____,
by _____

Individually, or as _____ for _____

personally known or produced the following type of identification: _____

Signature of Notary Public: _____

Printed name: _____

(SEAL)

VERIFICATION PURSUANT TO SECTION 92.525, FLORIDA STATUTES

Under penalties of perjury, I declare that I have read the foregoing and that the facts stated in it are true, to the best of my knowledge and belief.

Signature(s) of Owner(s) or Owner(s)' Authorized Officer/Director/Partner/ Manager who signed above:

By _____ By _____

(Address)

3 - ___ THWN CU
TO FPL

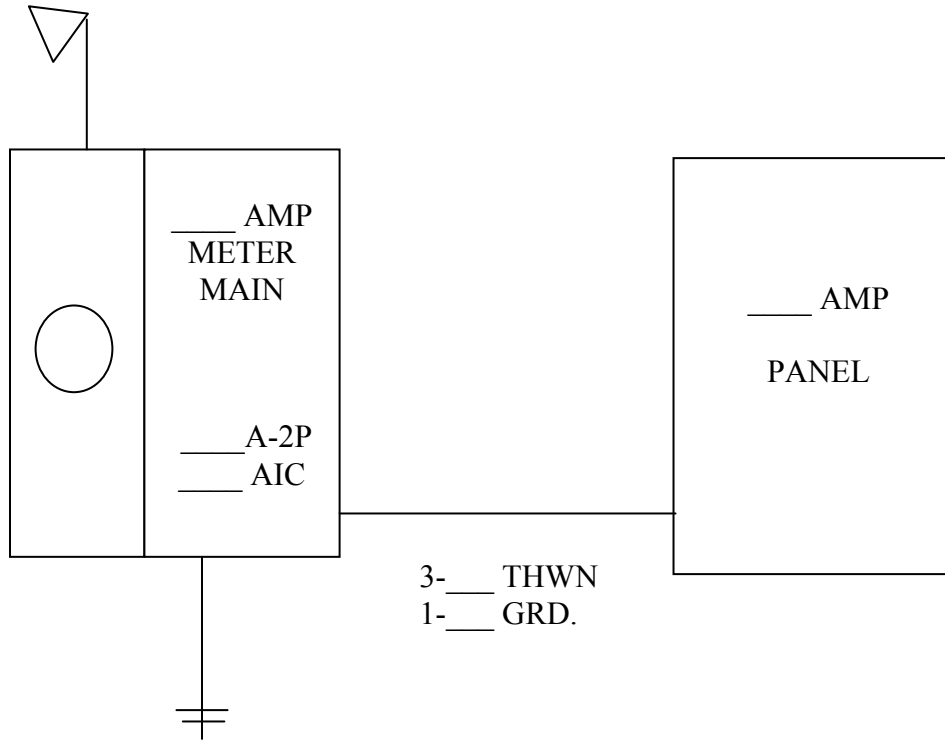

1 # ___ to CWP & (1) 5/8 X 8' GRD ROD

Print _____

Sign _____

Notary _____

Sworn to and subscriber before me this ___ day of ___ 20__ A.D.

(SEAL)

MY COMMISSION EXPIRES _____